



Electric Storage Water Heater

SLIM2 LUX-D WI-FI



SLIM2 LUX-D WI-FI

Electric Storage Water Heater

20 / 30

ELEGANT AND SMART USE OF SPACE

- / **Voice control:** integration with the main smart home platforms: AMAZON ALEXA and GOOGLE ASSISTANT
- / **Smart connectivity:** Water temperature always under control thanks to the Ariston Net app
- / **Digital display** for precise temperature reading (1°C accuracy)
- / **ECO EVO function** reduce energy consumption w/o compromising on comfort (available from APP).
- / **TitanShield technology** for best tank protection thanks to titanium enameled and enhanced Mg anode
- / **Scalding prevention indicator** to prevent risk of scalding
- / **Titanium heating element** ensures heating performance during the whole product life with **LIFETIME WARRANTY**
- / **AG+ technology** inhibits bacteria proliferation for better hygiene



VOICE CONTROL



WIFI ENABLED WITH VOICE CONTROL



DIGITAL DISPLAY



SMART FUNCTIONING WITH ECO EVO



TITANSHIELD TECHNOLOGY



SCALDING PREVENTION INDICATOR



LONGLASTING TITANIUM HEATING ELEMENT LIFETIME WARRANTY



FOR GREATER HYGIENE

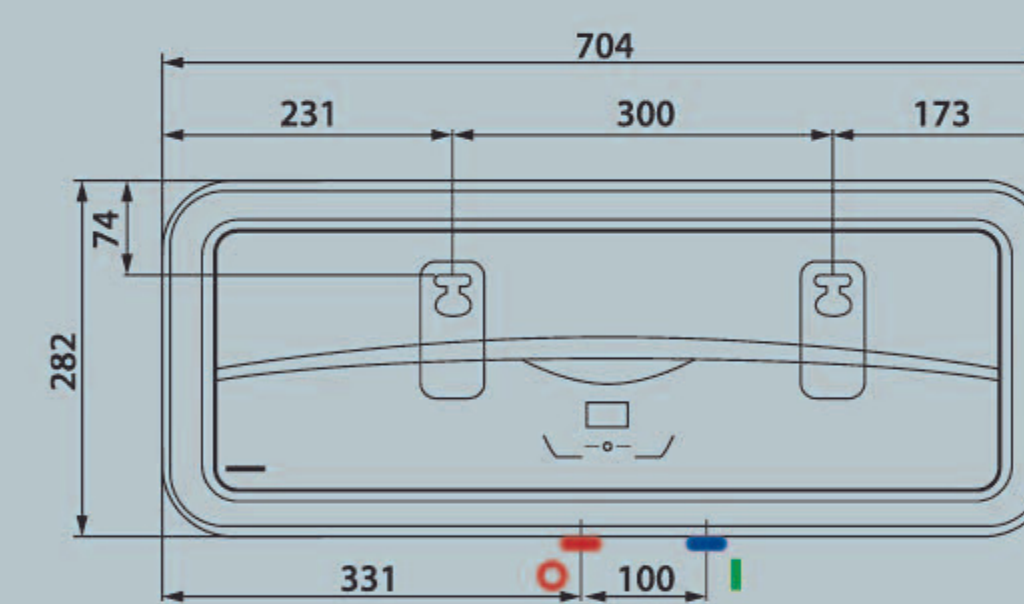

20L

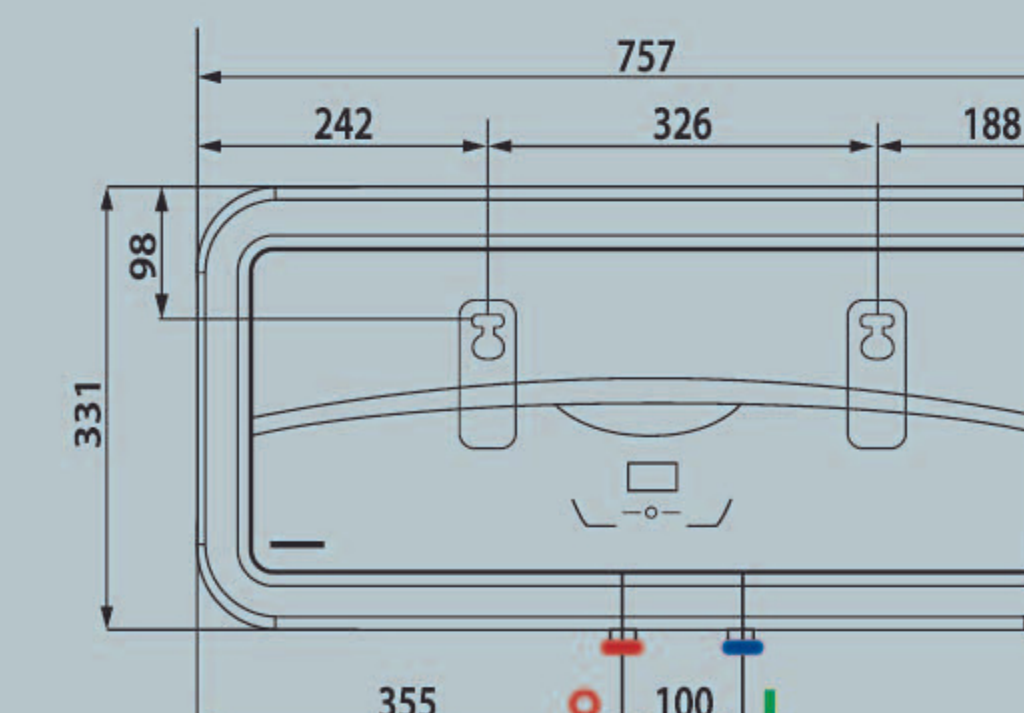
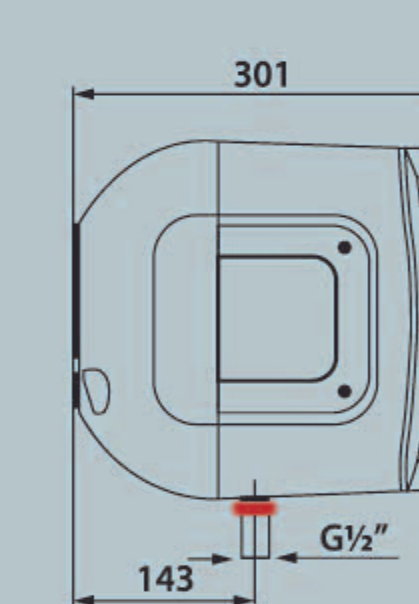

30L

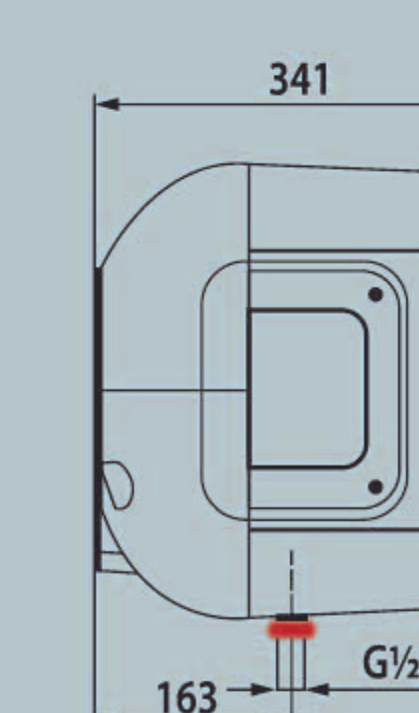

- Cold water inlet G 1/2
- Hot water outlet G 1/2

TECHNICAL DATA

		SL2 20 LUX-D WI-FI	SL2 30 LUX-D WI-FI
Capacity	(L)	20	30
Power	(kW)	2.5	2.5
Voltage	(V)	230	230
Heating time (ΔT=35°C)	(h:min)	0:19	0:29
Max working temperature	(°C)	80	80
Max. working pressure	(bar)	7.5	7.5
IP Protection	(IPX)	1	1
Heating element	Material	Titanium	Titanium
Net Weight	(Kg)	11.8	15

CODE	3180814	3180815
------	---------	---------

