



THE BEAUTY OF SIMPLICITY

MODEL: HB FG 3060 TN VSB FLUSH HOB



PERFORMANCE:

- 60cm Gas Hob
- 3 Burners
 - Front Left: Semi Rapid Burner - 1.75kW
 - Rear Left: Auxiliary Burner - 1.0kW
 - Right: Triple Ring Burner - 3.4kW

TECHNICAL INFORMATION:

- Product Dimension (WxDxH): 580 x 500 x 120mm
- Cut-Out Dimension (WxD): 563 x 483mm

PRODUCT FEATURES:

- Cast Iron Pan Supports with Wok Adapter
- Fully Sealed Burner Base
- Battery Ignition
- Flame Failure Safety Devices
- Stainless Steel

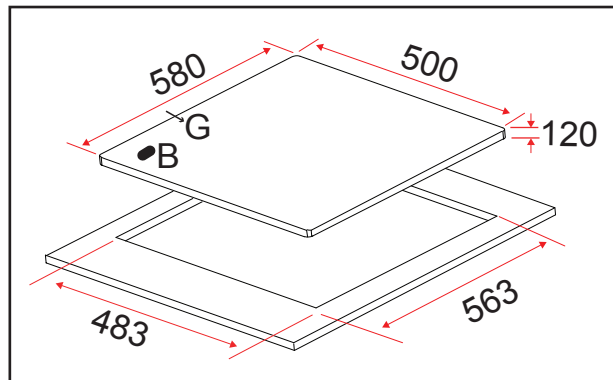

Note:

G= Gas Inlet / B=Battery Box

Dimension are in "mm"