

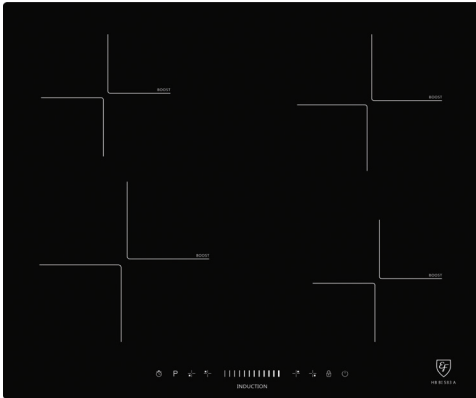

THE BEAUTY OF SIMPLICITY

MODEL: HB BI 583 A INDUCTION HOB



PERFORMANCE:

- 60cm Induction Domino Hob
- German SCHOTT CERAN Glass
- 4 Induction Zones
 - Front Left: Ø210mm - 1.8kW (Booster 2.1kW)
 - Front Right: Ø160mm - 1.2kW (Booster 1.5kW)
 - Rear Left: Ø160mm - 1.2kW (Booster 1.5kW)
 - Rear Right: Ø180mm - 1.8kW (Booster 2.1kW)

TECHNICAL INFORMATION:

- Product Dimension (WxDxH): 590 x 520 x 58mm
- Cut-Out Dimension (WxD): 560 x 490mm
- Total power: 7.2kW (2.8kW, 3.5kW, 6.0kW)
- 220~240V/50Hz

PRODUCT FEATURES:

- Power Management to limit the max. power to 3.4kW
- Sensor sliding touch control
- Pan recognition sensor
- 99 mins time control for all zones
- 9 levels cooking
- Booster function
- Overflow safety device
- Residual heat indicator
- Child lock
- Automatically safety switch off

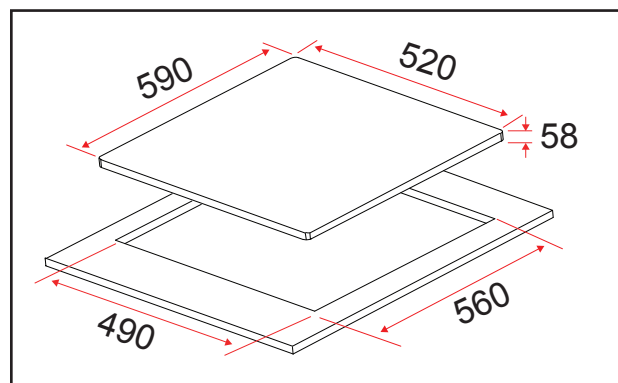

SCHOTT
CERAN