

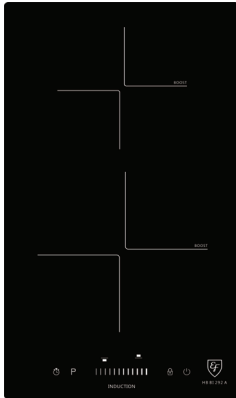

THE BEAUTY OF SIMPLICITY

MODEL: HB BI 292 A INDUCTION HOB



PERFORMANCE:

- 30cm Induction Domino Hob
- German SCHOTT CERAN Glass
- 2 Induction Zones
 - Front: Ø210mm - 1.8kW (Booster 2.1kW)
 - Rear: Ø160mm - 1.2kW (Booster 1.5kW)

TECHNICAL INFORMATION:

- Product Dimension (WxDxH): 290 x 520 x 58mm
- Cut-Out Dimension (WxD): 270 x 490mm
- Total power: 3.4kW
- 15 Amp/ 220~240V/50Hz

PRODUCT FEATURES:

- Power Management to limit the max. power to 3.4kW
- Sensor sliding touch control
- Pan recognition sensor
- 99 mins time control for all zones
- 9 levels cooking
- Booster function
- Overflow safety device
- Residual heat indicator
- Child lock
- Automatically safety switch off

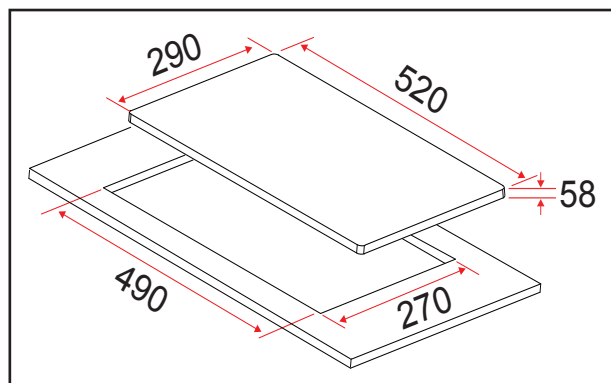

SCHOTT
C E R A N