



THE BEAUTY OF SIMPLICITY

MODEL: EFH 9730 HM VGB GLASS GAS HOB



PERFORMANCE:

- 86cm Gas Hob
- 3 Burners:
 - Left: Triple Ring Burner - 3.4kW
 - Center: Semi Rapid Burner - 1.75kW
 - Right: Triple Ring Burner - 3.4kW

TECHNICAL INFORMATION:

- Product Dimension (WxDxH): 860 x 500 x 60mm
- Flexible Cut-Out Dimension (WXD):
 - W722~W810 x D428~D460mm

PRODUCT FEATURES:

- Cast Iron Pan Supports with Wok Adapter
- Fully Sealed Burner Base
- Battery Ignition
- Flame Failure Safety Devices
- Black Tempered Glass

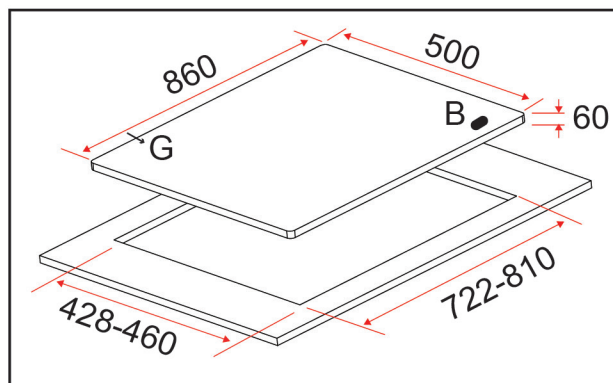

Note:

G= Gas Inlet / B=Battery Box
Dimension are in "mm"